

Operating, Servicing, and Safety Manual

**Model # 900
90° Hydraulic Bender**

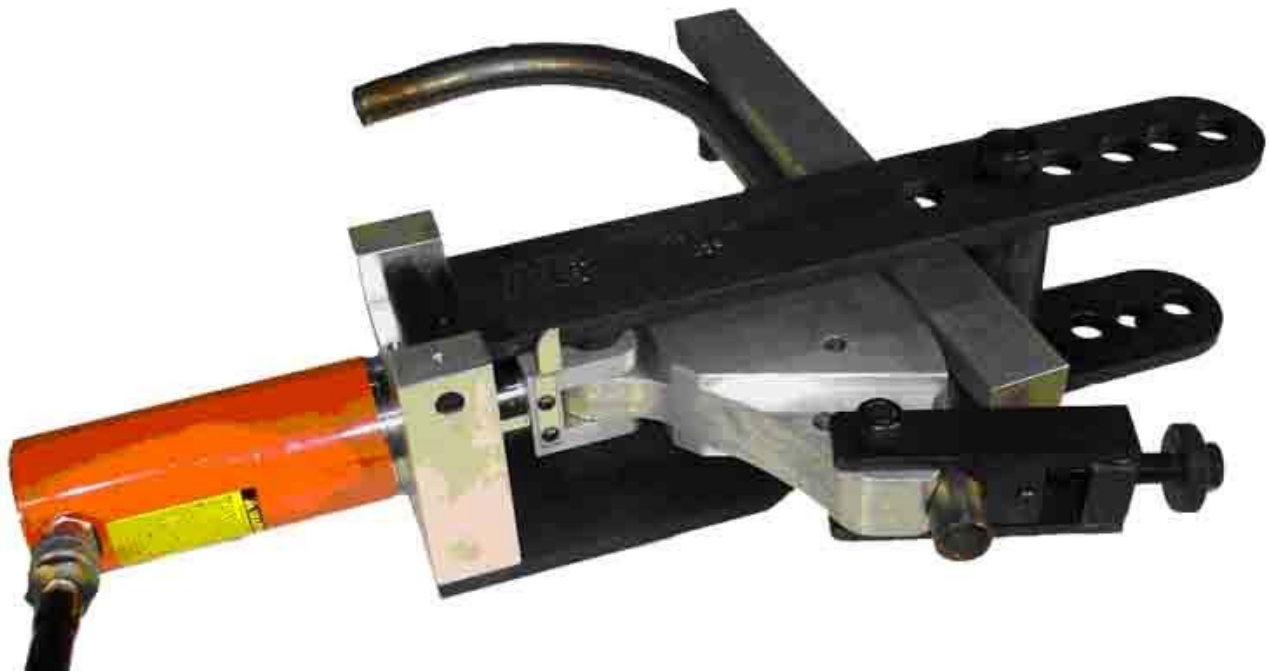

CAUTION: Read and Understand

These Operating, Servicing, and
Safety Instructions, Before Using
This Machine.

1-800-467-2464

10 Cooperative Way Wright City, MO 63390

P.O. Box 110 Foristell, MO 63348

1-636-745-7757 Fax 1-636-745-2874

www.mittlerbros.com

Table of Contents

- Safety Pg.3
- Hydraulic Safety Precautions Pg.4
- Hydraulic System Operation Pg.5
- Machine Set up Pg.6
- Operation Pg.7
- Math Formulas Pg.8-11
- Technical Diagram Pg.12
- Optional Equipment Pg.13-15

SAFETY

The purpose of the safety section of this manual is to inform operators and maintenance personnel of the precautions to be taken while operating or servicing the machine. The following are a few basic guidelines to follow, but as with any type of machinery good judgment and a safe attitude should be applied at all times.

1. Always disconnect power, lock-out and tag-out machine per OSHA regulations before attempting to service this machine.
2. Always wear safety glasses or other approved eye protection while operating or servicing the machine.
3. Keep all body parts and any foreign objects away from moving parts. Do not reach into the machine without first disconnecting all power sources.
4. Do not attempt to override any safety device on the machine.
5. Do not operate the machine if it has been damaged or is not operating properly.
6. Do not wear jewelry (watches, rings, necklaces, etc.), or loose fitting clothing while operating or servicing the machine.
7. The machine should only be operated or serviced by properly trained, authorized personnel.
8. Replacement parts should have the same specification and operation as the original parts on the machine.
9. Before starting the machine be sure it is set up properly.
10. The machine and work area should be kept neat and clean.
11. Do not operate or service any machine while under the influence of drugs or alcohol.

NOTE: THESE SAFETY RULES ARE FOR YOUR BENEFIT TO HELP PREVENT INJURY TO YOURSELF AND/OR YOUR CO-WORKERS. REVIEW ALL SETUP AND OPERATING PROCEDURES, WHETHER COVERED OR NOT, IN THIS MANUAL TO HELP INSURE SAFE OPERATION OF THE MACHINE.

HYDRAULIC SAFETY PRECAUTIONS

WARNING

General Operation

- All WARNING statements must be carefully observed to help prevent personal injury.
- Before operating the pump, all hose connections must be tightened with the proper tools. Do not over tighten. Connections should only be tightened securely and leak-free. Over tightening can cause premature thread failure or high pressure fittings to split at pressures lower than their rated capacities.
- Should a hydraulic hose ever rupture, burst, or need to be disconnected, immediately shut off the pump and release all pressure. Never attempt to grasp a leaking pressurized hose with your hands. The force of escaping hydraulic fluid could cause serious injury.
- Do not subject the hose to potential hazard such as fire, sharp surfaces, extreme heat or cold or heavy impact. Do not allow the hose to be altered or kink, twist, curl, crush, cut, or bend so tightly that the fluid flow within the hose is blocked or reduced. Periodically inspect the hose for wear, because any of these condition's can damage the hose and possibly result in personal injury.
- Do not use the hose to move attached equipment. Stress can damage hose and possibly cause personal injury.
- Hose material and coupler seals must be compatible with the hydraulic fluid used. Hoses also must not come in contact with corrosive materials such as creosote-impregnated objects and some paints. Consult the manufacturer before painting a hose. Hose deterioration due to corrosive materials can result in personal injury. Never paint the couplers.
- Inspect machine for wear, damage, and correct function before each use. Do not use machinery that is not in proper working order, but repair or replace it as necessary.
- Replace worn or damaged safety decals.
- Modification of a product requires written Power Team authorization.
- Use only components with the same pressure rating when assembling a system or machine.

Pump

- Do not exceed the hydraulic pressure rating noted on the pump data plate or tamper with the internal high pressure relief valve. Creating pressure beyond the rated pressure can result in personal injury.
- Before replenishing the fluid level, retract the system to prevent overfilling the pump reservoir. An overfill can cause personal injury due to excess reservoir pressure create when cylinders are retracted.

Air Supply

- Shut off and disconnect the air supply when the pump is not in use or before breaking any connections in the system.

PREPARATION & SET-UP

Air Supply Hook-Up

Remove the thread protector from the air inlet of the pump. Select and install the threaded fittings which are compatible with your air supply fittings. The air supply should be 20 CFM (.57 M3/min.) and 100 PSI (7 BAR) at the pump to obtain the rated hydraulic pressure. Air pressure should be regulated to a maximum of 140 PSI (9 BAR). Secure your pump fitting to the air supply.

WARNING: If improperly used, pressurized equipment can be potentially hazardous. Therefore:

- Hydraulic connections must be securely fastened before building pressure in the system.
- Release all system pressure before loosening any hydraulic connection in the system.

Venting the Reservoir

To improve hydraulic fluid delivery and increase useable hydraulic fluid capacity, remove shipping plug and install filler/vent cap before using the pump.

HYDRAULIC SYSTEM

1. Remove the **RED Plug** in the pump assembly and replace with the supplied **BLACK plug**. This is the reservoir venting system and damage or inoperability may result if not changed out.

2. Attach the hydraulic hose to the pump. Be sure to use a quality thread sealer on both connections

3. Attach an air line fitting for your shop air to other end of the pump.

4. Push the pump foot pedal to the release position (TOE END) to relieve all internal pressure.

5. Push the MALE hose end, from the pump, into the FEMALE Cylinder fitting.

Female End

Male End

Retainer Collar



6. Thread the retainer collar hand tight. **NOTE:** This procedure will insure that the male & female fittings positively seat against each other, eliminating any possibility of air locking. **CAUTION** Failing to follow this procedure may cause the cylinder to not retract and / or leak.

BLEED THE CYLINDER

7. Connect a compressed air supply (90PSI) to the pump.

8. Elevate the pump and hose above the cylinder.

9. Push the hydraulic pump pedal **HEEL END** to actuate the cylinder. Run the cylinder out about half way. Release the pump by pressing on the **TOE END** of the pedal. Repeat this process three or four times or until the ram cylinder movement is smooth.

Pump Assembly

RED Plug should be changed to BLACK Plug

Hydraulic Hose

Air Connector

Push Down to Release Pressure

TOE END
Retract

HEEL END
Pump

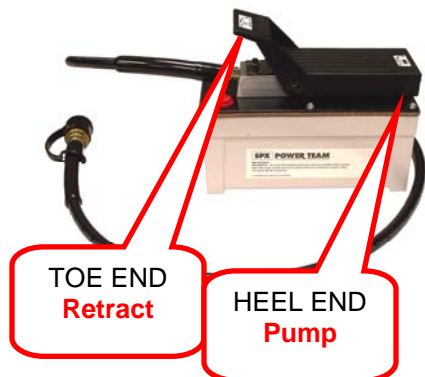
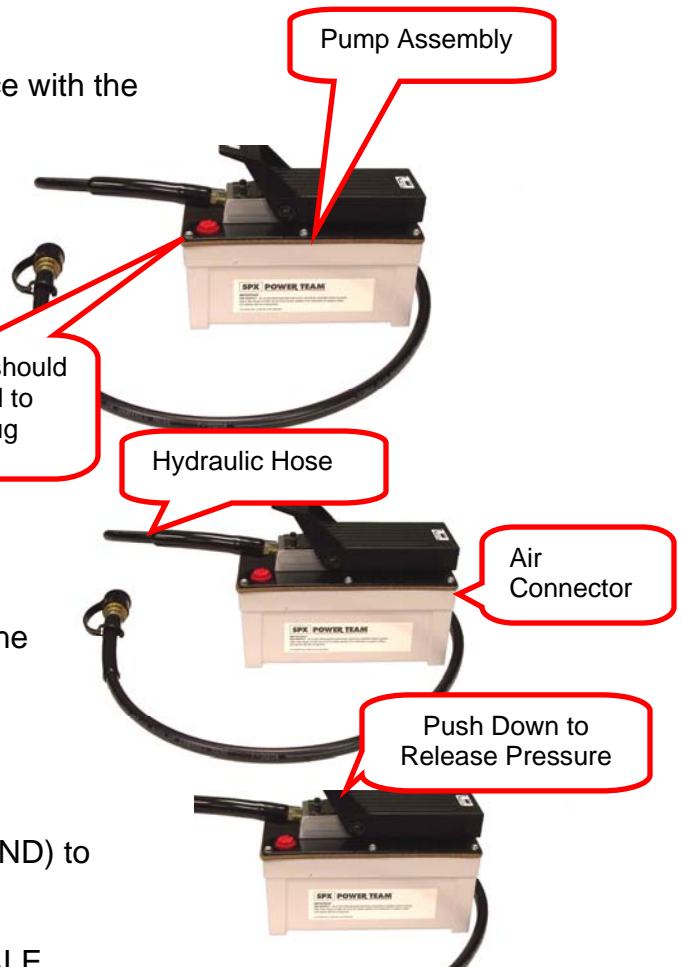

MACHINE SETUP

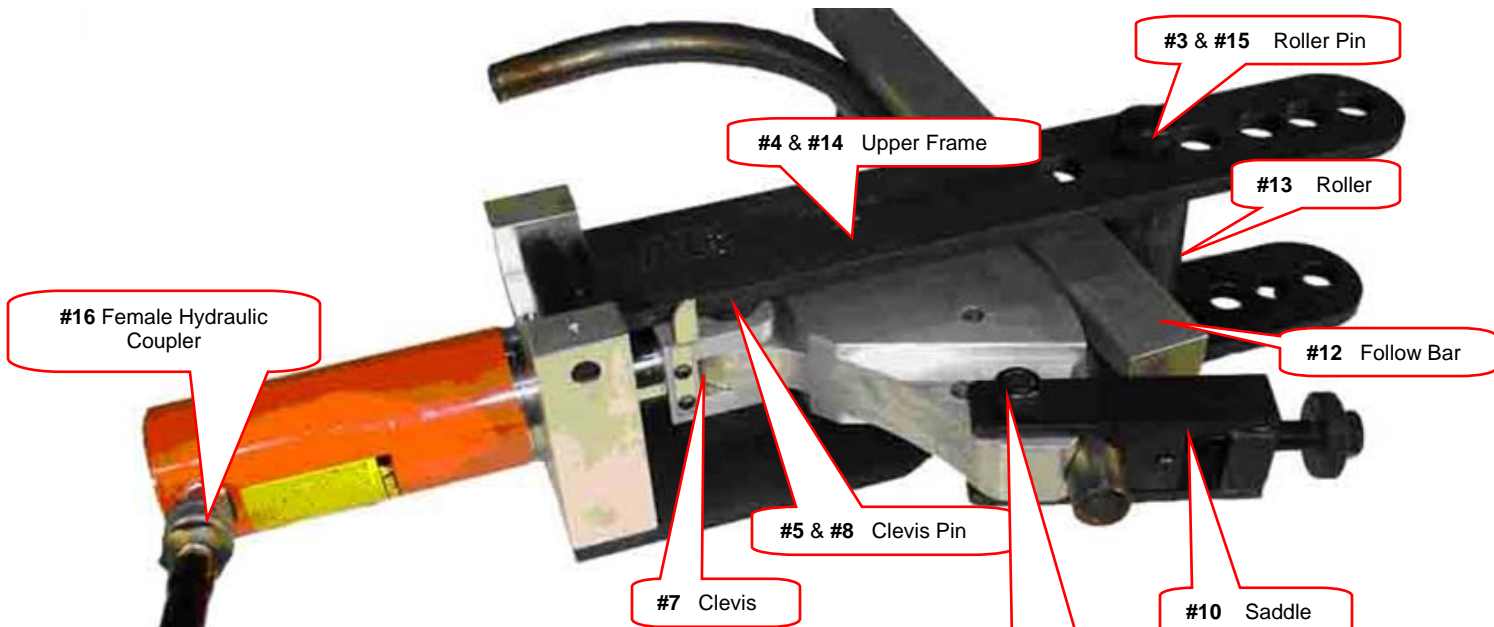

1. Remove machine from packaging.
2. Place machine on table or floor.
3. Remove roller pin.
4. Rotate upper frame out of the way.
5. Remove clevis pin.
6. Remove bender shoe & follow bar from packaging.
7. Insert shoe into clevis.

Note: Shoe can be installed to rotate in either direction to complete the bends.

8. Insert clevis pin.
9. Remove saddle pin from adjustable saddle.
10. Place saddle on to shoe as shown.
11. Insert saddle pin into saddle and shoe.

CAUTION: Be sure pin is completely through bottom saddle arm.

12. Place follow bar on to machine as shown.
13. Slide roller as close as possible to follow bar.

Note: Lubricate (oil) roller Top / Bottom and Inside Diameter

14. Close the upper frame.

15. **Note:** Lubricate (oil) Pin Outside Diameter Insert roller pin through the upper frame, roller, & lower frame.

CAUTION: Be sure pin is completely through lower frame arm.

16. Machine is now ready for use.

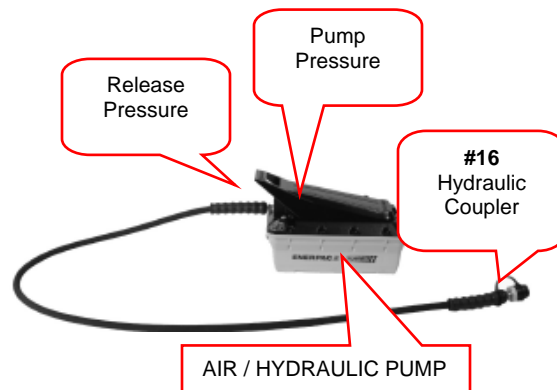

OPERATION

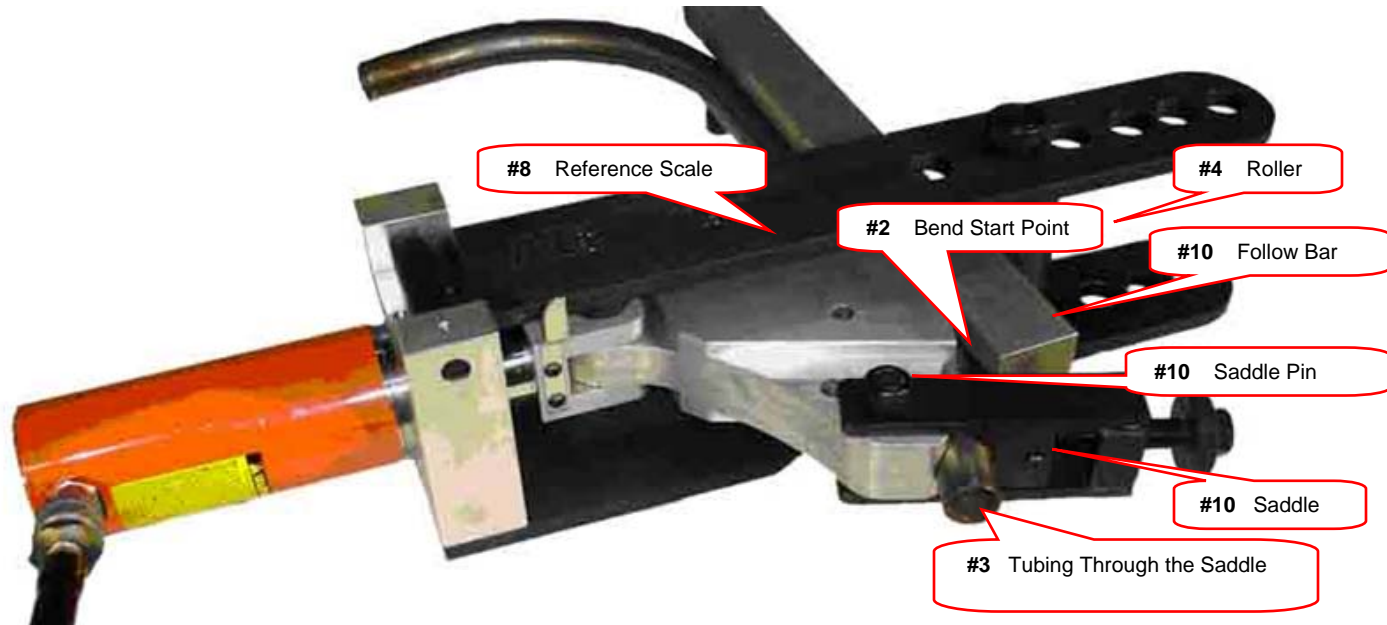

#5 Shoe Start Point

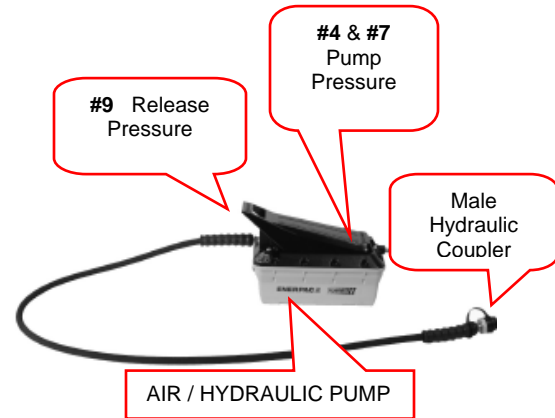

1. Insert tubing into channel in the shoe, follow bar, and adjustable saddle.

CAUTION: Be sure roller pin is completely through lower frame

2. Align the bend start point marked on tubing to the bend start point on the bender shoe.

3. Make sure that tubing is sticking all the way through the adjustable saddle.

4. Tighten adjustable saddle "V" block against tubing.

CAUTION: Be sure pin is completely through bottom saddle arm.

5. Align the front edge of the follow bar with the bend start point of the bending shoe.

6. Press the foot pedal on the hydraulic pump, using short bursts until the bending shoe and follow bar are close to the roller.

7. Check your tubing to make sure that your tubing start point is still aligned with the shoe start point.

8. Now make your bend by pressing down on the foot pedal heel on the hydraulic unit until the desired angle is reached.

9. It usually is necessary to bend tubing past the desired angle a few degrees to account for tubing spring back. **Note:** Record location of reference scale pointer to reference scale to assist in completing future bends to same degree of bend with same tubing material, size, and wall thickness. Then you can bend the next pieces to that same reference scale mark.

10. When desired angle is reached, press hydraulic pump foot pedal toe to release pressure.

11. Turn adjustable saddle knob counterclockwise to remove saddle pin, saddle and follow bar.

12. Repeat these steps with each additional bend.

CORRECTED MATHEMATICAL FORMULA FOR HYDRAULIC TUBING BENDER WHEN USING INSTRUCTION VIDEO

The following formula should be used to determine the start point for each required bend.

The example will be for a Double Bevel Bend

- L1 = 26 25 degree angle
- L2 = 15 65 degree angle
- L3 = 39 65 degree angle
- L4 = 15 25 degree angle
- L5 = 26

Bend #1 Start Point:

$$\begin{aligned} &L1 - \frac{1}{2} \text{ developed length (DL25)} - \frac{1}{2} \text{ (Gain)} \\ &26'' - \frac{1}{2} (3.064'') - \frac{1}{2} (.050) \\ &26'' - 1.532'' - .025'' = 24.448 \end{aligned}$$

Bend #2 Start Point:

$$\begin{aligned} &L1 + L2 - \text{Gain 1} - \frac{1}{2} \text{ (DL65)} - \frac{1}{2} \text{ (Gain 2)} \\ &26 + 15 - .050 - \frac{1}{2} (7.941) - \frac{1}{2} (.973'') \\ &26 + 15 - .050 - 3.9705 - .48895 = 36.491 \end{aligned}$$

Bend #3 Start Point:

$$\begin{aligned} &L1 + L2 + L3 - \text{Gain 1} - \text{Gain 2} - \frac{1}{2} \text{ (DL65)} - \frac{1}{2} \text{ (Gain 3)} \\ &26 + 15 + 39 - .050'' - .978 - \frac{1}{2}(7.941) - \frac{1}{2} (.972'') \\ &26 + 15 + 39 - .050'' - .978 - 3.9705 - 0.486 = 74.515 \end{aligned}$$

Bend #4 Start Point:

$$\begin{aligned} &L1 + L2 + L3 + L4 - \text{Gain 1} - \text{Gain 2} - \text{Gain 3} - \frac{1}{2} \text{ (DL25)} - \frac{1}{2} \text{ (Gain 4)} \\ &26 + 15 + 39 + 15 - .050 - .978 - .978 - \frac{1}{2} (3.054) - \frac{1}{2} (0.497) \\ &26 + 15 + 39 + 15 - .050 - .978 - .978 - 1.527 - 0.025 = 91.442 \end{aligned}$$

GAIN FACTORS

Degree of Bend	Multiplier
1	.0000
2	.0000
3	.0000
4	.0000
5	.0000
6	.0001
7	.0001
8	.0003
9	.0003
10	.0005
11	.0006
12	.0008
13	.0010
14	.0013
15	.0015
16	.0018
17	.0022
18	.0026
19	.0031
20	.0036
21	.0042
22	.0048
23	.0055
24	.0062
25	.0071
26	.0079
27	.0090
28	.0100
29	.0111
30	.0126

Degree of Bend	Multiplier
31	.0136
32	.0150
33	.0165
34	.0181
35	.0197
36	.0215
37	.0234
38	.0254
39	.0276
40	.0298
41	.0322
42	.0347
43	.0373
44	.0400
45	.0430
46	.0461
47	.0493
48	.0527
49	.0562
50	.0600
51	.0637
52	.0679
53	.0721
54	.0766
55	.0812
56	.0860
57	.0911
58	.0963
59	.1018
60	.1075

Degree of Bend	Multiplier
61	.1134
62	.1196
63	.1260
64	.1327
65	.1397
66	.1469
67	.1544
68	.1622
69	.1703
70	.1787
71	.1874
72	.1964
73	.2058
74	.2156
75	.2257
76	.2361
77	.2470
78	.2582
79	.2699
80	.2891
81	.2944
82	.3074
83	.3208
84	.3347
85	.3491
86	.3640
87	.3795
88	.3955
89	.4121
90	.4292

GAIN = GAIN FACTOR FOR DEGREE OF BEND X RADIUS

EXAMPLE:
FIND THE GAIN FOR AN 85 DEGREE BEND
USING A 7 INCH RADIUS

$$\text{GAIN} = .3491 \times 7 = 2.4437 \text{ OR } 2 \frac{7}{16}$$

TABLE FOR OFFSET MULTIPLIER

Degree of Bend	Multiplier
1	57.30
2	28.65
3	19.11
4	14.33
5	11.47
6	9.57
7	8.21
8	7.18
9	6.39
10	5.76
11	5.24
12	4.81
13	4.45
14	4.13
15	3.86
16	3.63
17	3.42
18	3.24
19	3.07
20	2.92
21	2.79
22	2.67
23	2.56
24	2.46

Degree of Bend	Multiplier
25	2.37
26	2.28
27	2.20
28	2.13
29	2.06
30	2.00
31	1.94
32	1.89
33	1.84
34	1.79
35	1.74
36	1.70
37	1.66
38	1.62
39	1.59
40	1.56
41	1.52
42	1.49
43	1.46
44	1.44
45	1.41
46	1.39
47	1.37
48	1.35

DISTANCE BETWEEN BENDS = OFFSET MULTIPLIER FOR DEGREE X OFFSET HEIGHT

EXAMPLE:

FIND THE DISTANCE BETWEEN BENDS FOR A 15 INCH OFFSET USING 25 DEGREE BENDS.

DISTANCE BETWEEN BENDS = $2.37 \times 15 = 35.55$ OR $35 \frac{9}{16}$

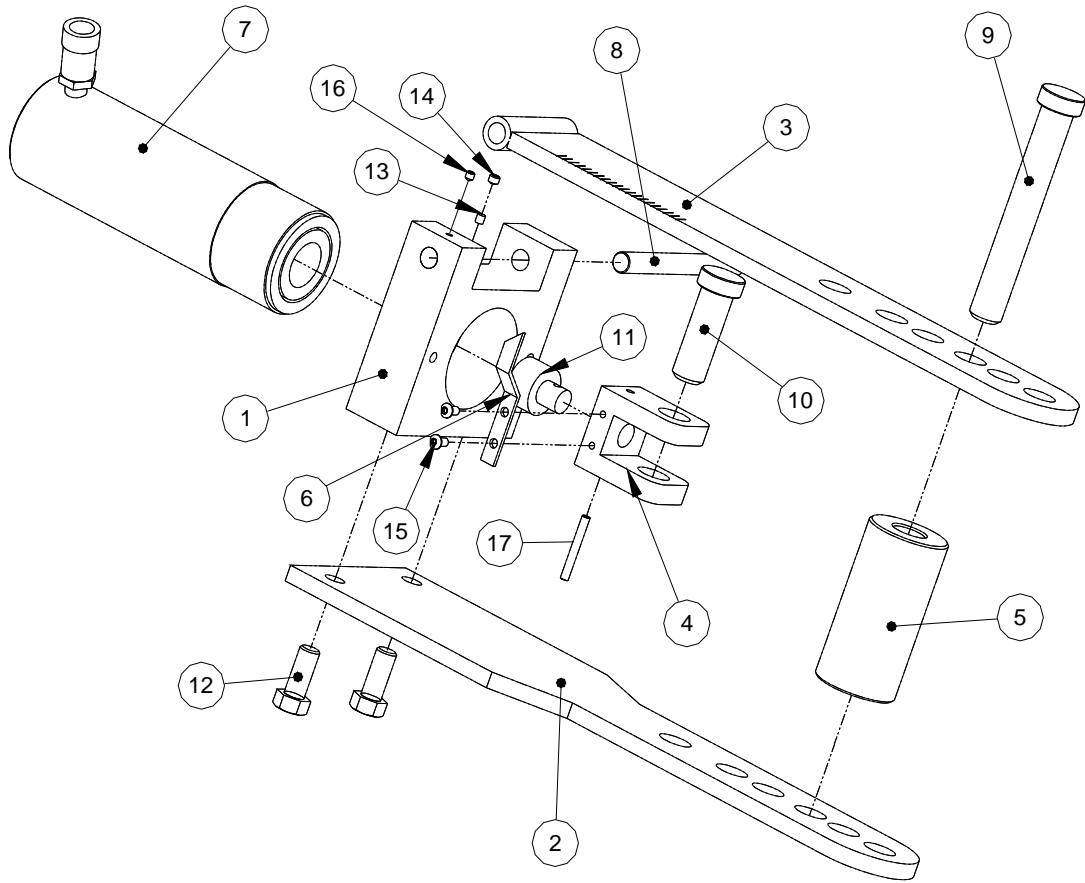

ITEM NO.	QTY	PART NO.	PRICE
1	1	900-003 Cylinder Mount Block	\$200.00
2	1	900-002 Lower Frame	\$100.00
3	1	900-005 Upper Frame	\$125.00
4	1	900-004 Shoe Clevis	\$100.00
5	1	900-007 Follow Bar Roller	\$75.00
6	1	900-018 Scale Pointer	\$25.00
7	1	900-502 Hydraulic Cylinder	\$530.00
8	1	900-008-C Hinge Pin	\$25.00
9	1	900-008-A Roller Pin	\$35.00
10	1	900-008-B Clevis Pin	\$30.00
11	1	900-006 Clevis Adapter	\$50.00
12	2	05/8-11x1-1/2 Hex Head	\$10.00
13	1	Delrin	\$1.00
14	1	5/16-18x1/4 Set Screw	\$1.00
15	2	1/4-20x1/2 Button Head	\$2.00
16	1	1/4-20x1/4 Set Screw	\$1.00
17	1	Roll Pin	\$1.00

1-800-467-2464

www.mittlerbros.com

Optional Equipment

Adjustable Saddles for 90 & 180 Hydraulic Benders



Saddle eliminates the need for individual saddles for each tubing size. Two sizes handle 5/8" to 1-3/4" Round & Square Tubing.

Advantages

- Securely holds each tube, eliminates tube creep
- Easy Release "V" Block eliminates Stuck Saddle from tube spring back
- Easier Bend-to-Bend Alignment with light pressure on tube

Small & Medium Adjustable Saddles included with purchase of new Hydraulic Tube Bender since December 2006.

Adjustable Saddles must be purchased with new shoe sets if Bender was built before December 2006.



[2500-300](#)

Adjustable Saddle, Small 5/8" to 1-3/8"

\$95.00

[2500-301](#)

Adjustable Saddle, Medium 1-1/2 to 1-3/4"

\$95.00

[2500-302](#)

Adjustable Saddle, Large 2" OD

\$75.00

Bend Stop for 180 Bender

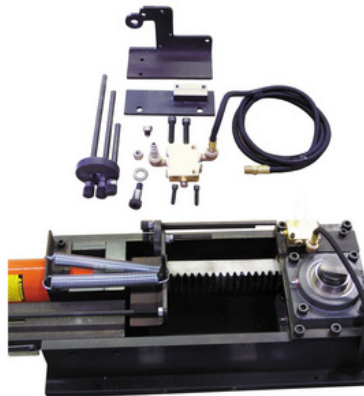

[2500-400](#)

Bend Stop Kit for 180* Bender

\$325.00

Pumps



[900-504-6](#)

Air Hydraulic Pump, 6' Hose & Fitting

\$595.00



[900-508-6](#)

Electric Hydraulic Pump, Hose & Fittings 6'

\$1,580.00



[900-D](#)

Digital Read Out for 90° Hydraulic Tube Bender

\$365.00

[900-500-DVD](#)

Tubing Bending DVD for 90 Degree Hydraulic Tube Bender

\$40.00

Bend Protractors



[2100-4](#)

4" Protractor Assembly

\$100.00



[2100-5](#)

5" Protractor Assembly

\$110.00



[2100-6](#)

6" Protractor Assembly

\$120.00



[2100-7](#)

7" Protractor Assembly

\$130.00



[2100-8](#)

8" Protractor Assembly

\$140.00



[2100](#)

4" Thru 8" Protractor Set

\$510.00

BEND-TECH EZ

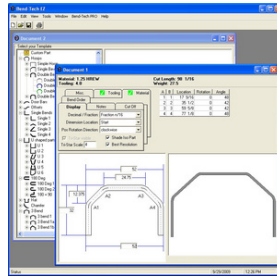

Designed for simple 2d parts!



900-510

Bend-Tech EZ Software

\$69.00

BEND-TECH EZ-3D

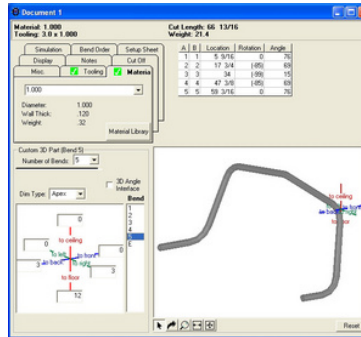

Designed for 3d bending, with 360 degree part rotation!



900-511

Bend-Tech EZ-3D Software

\$149.00

BEND-TECH PRO

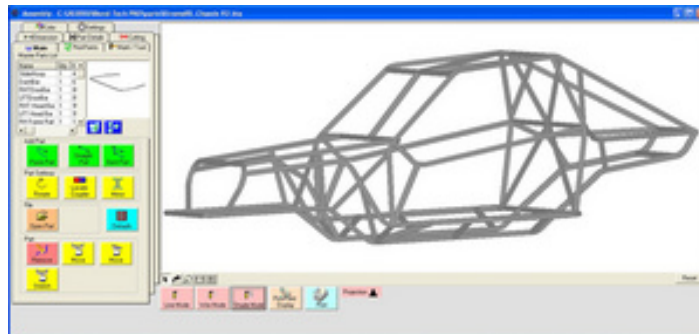

Full 3d Assembly & Manufacturing Instructions, plus all EZ features!



900-512

Bend-Tech Pro Software

\$275.00



900-513

Bend-Tech SE Software

\$399.00

CAUTION: Read and Understand

These Operating, Servicing, and
Safety Instructions, Before Using
This Machine.

1-800-467-2464

10 Cooperative Way Wright City, MO 63390

P.O. Box 110 Foristell, MO 63348

1-636-745-7757 Fax 1-636-745-2874

www.mittlerbros.com